

Saramonic

Audio Adapter

The SARAMONIC SR-AX101 is a 2-channel XLR audio adapter ideal for any compact camcorder or DSLR camera with a built-in microphone jack. It enables you to acquire professional audio from XLR outputs into a camcorder that has a 3.5mm (1/8") audio input.

COPYRIGHT 2011-2021 SARAMONIC INTERNATIONAL

A brand of DSQN

Web: www.saramonic.com

Email: info@saramonic.com

User Manual

1 PRODUCT INTRODUCTION

1.1 General Introductions

The SARAMONIC SR-AX101 is a 2-channel XLR audio adapter ideal for any compact camcorder or DSLR camera with a built-in microphone jack. Wide-variety of audio devices like balanced XLR microphones, wireless microphones, external audio mixers, preamplifiers and more can be connected to the camera via this adapter.

The SR-AX101 enables you to acquire professional audio from XLR outputs into a camera that has a 3.5mm (1/8") audio input. The passive operation provides you superb sound quality with an extremely wide dynamic range, and no batteries or power source are needed.

The SR-AX101 is simple to set up and use. With the trim control knobs for each channel, you can adjust the recording levels. It's a compact and economical way to add excellent audio to your camcorder.

1.2 Product Structure

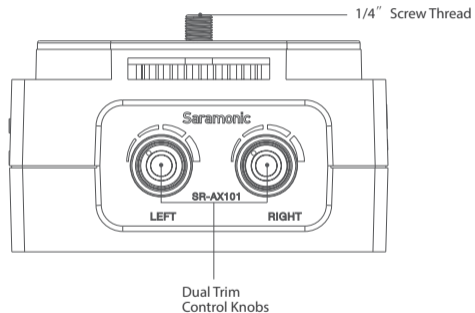

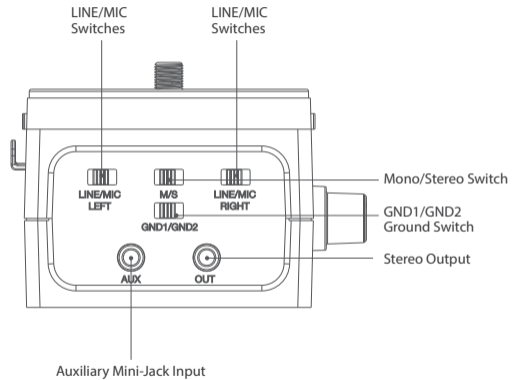
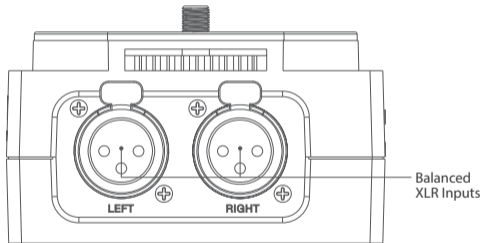

1.3 Highlights

1.3.1 Inputs

- ※ One 1/8" (3.5 mm) Auxiliary Mini-Jack Input
- ※ Two balanced XLR inputs

Note: The AUX Input is ideal for connecting wireless devices with a 3.5mm output. As it sends signal to the right channel, please do not use the right XLR Input while using the AUX Input.

1.3.2 Output

- ※ One stereo 1/8" (3.5 mm) Mini-Jack output

1.3.3 Dual Trim Control Knobs

- ※ Adjust the signal of each channel to the optimum recording levels

1.3.4 Mono /Stereo Switch

- ※ Select mono or stereo output mode

The Mono mode is for one mono microphone recording. It can send the mono audio signal to each channel and output stereo audio signal. The Stereo mode is for two channels recording, it provides two separate channels of audio.

1.3.5 LINE / MIC Switches

- ※ Select LINE or MIC levels

The MIC level is for microphones or wireless system.

The LINE level is for mixers and other audio devices with a line level output. Set the LINE/MIC switch to LINE to attenuates the signal about 40dB

1.3.6 GND1/GND2 Ground Switch

- ※ Eliminate ground hum and noise for getting the best sound

GND1: Separate the output signal ground from the input signal ground. To avoid the noise of the input signal passing to the output signal. This noise is usually caused by AC power, for instance, mixer with AC power adapter.

GND2: Connect the output signal ground to the input signal ground.

1.3.7 Plastic Chassis With a Tripod Socket

1.3.8 Passive Circuit Make it Noise Free

1.3.9 No Power or Batteries are Needed

1.3.10 Easy to Set Up and Use

1.4 Specifications

Input Level	MIC: -35 dBu	LINE: -10 - +4 dBu
Output Level	General Mic Levels	
Frequency Response	10Hz to 100kHz (+/-1.5 dB)	
Dimensions	87 (L) x 80(W) x 52(H) mm	
Weight	191g (6.7oz.)	

2 Quick Start Guide

a) Attach the SR-AX101 to the base of the camera. Spin counter-clockwise to tighten up the adapter with the camera. Mount the adapter to a tripod with the tripod socket on the bottom of the adapter.

b) Connect the supplied signal transmission line from the output jack(OUT) of adapter to the MIC input of camera. If there is a MIC / Line switch on the camera, select it to MIC.

Note: Please switch off the AGC function of your camera if possible.

c) Connect balanced XLR microphones, wireless mics or other audio sources to the LEFT and RIGHT XLR or AUX inputs on the SR-AX101.

d) Set the LINE/MIC switch.

When using microphones and wireless systems, set to MIC for microphone. When using other audio devices, set to LINE for Line.

e) Set the M/S switch.

When using one channel, switch to M for mono.

When using two channels, switch to S for stereo.

f) Set the GND1/GND2 switch

Set the ground switch to GND1 initially. When recording, if there are some odd noises from ground loop, you could switch it to GND2. Please switch it flexibly to the side with a better sound quality.

g) In case of any distortion, you should initially set the LEFT and RIGHT trim controls fully clockwise. When test recording, you could adjust the knobs flexibly to get the the optimum signal levels.

h) If your camera has a headphone jack, you can plug an earphone into the headphone terminal on the camera to monitor the audio. Please make sure that both channels can be heard and adjust the trim controls if any distortion.

3 Warranty

3.1 Saramonic International provides one-year warranty under normal use and lifelong paid maintenance from the date you purchase this product.

3.2 Saramonic International will repair or replace the product that under the warranty for free during the one-year valid period, but customers should pay for shipping and insurance charges for returning the product to Saramonic International.

3.3 This warranty only applies where a defect has arisen, wholly or substantially, as a result of faulty manufacture, parts or workmanship during the warranty period.

3.4 This warranty does not cover:

a) All damages caused by human factors include using the products in abnormal conditions and operate the device without according to the user manual.

b) The guarantee is invalid if defect is caused by incorrect use, poor maintenance or if persons not authorized by Saramonic International have carried out alterations or repairs.

c) Damages caused by poor transportation after you purchased this product.

d) Force majeure such as fire, flood, lightning stroke, earthquake.

e) Customers who can not show valid invoice.

3.5 Wherever you purchased our products, you will be served very well at local retailer.

3.6 Saramonic International reserves all the rights for the ultimate interpretation.

4 Compatibility

Self-powered professional XLR microphones, wireless systems, other audio devices such as mixing boards and preamplifiers.

Any compact comcorder or DSLR camera with a microphone jack.

5 Packing List

One SR-AX101 main unit

One signal transmission line

User manual

Warranty card